



bigleaf
networks

Installation Guide

Switched High Availability

For use with BLR-112



Thank you for choosing Bigleaf!

Your Internet optimization service is only a few steps away! This booklet will walk you through the setup process to get your Bigleaf service up and running. The equipment shipped to you is pre-configured and ready for use, so you can install it right away.

Tech Support: (888) 244-3133

If you have any trouble connecting or you think there may be a problem with your Bigleaf service, please call us so we can help you immediately. For a routine request like a DNS change, feel free to email us.

Bigleaf Dashboard: app.bigleaf.net

PREP

Begin here when you are ready to get started. Before proceeding, verify that your Configuration Details card is included with your shipment.

1 Prepare Equipment



Gather Network Cables

Gather the needed number of CAT5e, CAT6, or Fiber patch cables to connect from the Bigleaf switches to each ISP modem or router, from switch to switch, and also to your firewall(s) or router(s). You will need 12 to 18 cables, depending on your specific setup.



Plan your power source

During the setup process, you will plug the Bigleaf routers and switches into a power source. We strongly recommend using two Uninterruptible Power Supplies (UPS), connecting one router and one switch to each. This will protect the router from power surges and brownouts.



Verify access to your firewall or router

Before you start the setup process, verify that you have access to edit your firewall or router configuration. You will update firewall settings with your new Bigleaf IP addresses in Step 10.

2 Consider IP-related Changes

If none of these apply, you may proceed to the Install section.



DNS Records

Do you have DNS records pointing at your existing ISP IP addresses? If so, you will need to plan to update those to your new Bigleaf IP addresses during the router install. A day or two before the install, you should lower the TTL for those records to a small value like 10 minutes to ensure a quick transition.



Mail Server

Are you hosting a mail server on-site? If so, Bigleaf will need to set up a reverse-DNS PTR record for the server: To set this up, email support@bigleaf.net with:

- The Bigleaf IP address that you will use for your mail server
- The full hostname of the mail server



VPNs

Do you have any VPNs, or other network resources that are statically configured with WAN IP addresses? If so, prepare to update these during Step 11 of the Install section.

INSTALL

Once you have completed all necessary prep steps, follow these steps to get your Bigleaf service up and running.

3 Get to Know the Switches

Use this overview to familiarize yourself with the general switch connection process. Steps 4 through 7 will provide a step-by-step breakdown of all hardware connections.

Switch Port Overview

Each port on a switch is designated for a specific device, as displayed to the right. Both Switch 1 and Switch 2 use this configuration.

Note that not all switch ports will be used on both switches. Non-redundant connections, such as ISP circuits and non-LACP enabled devices, will be staggered between the two switches in case of switch failure.

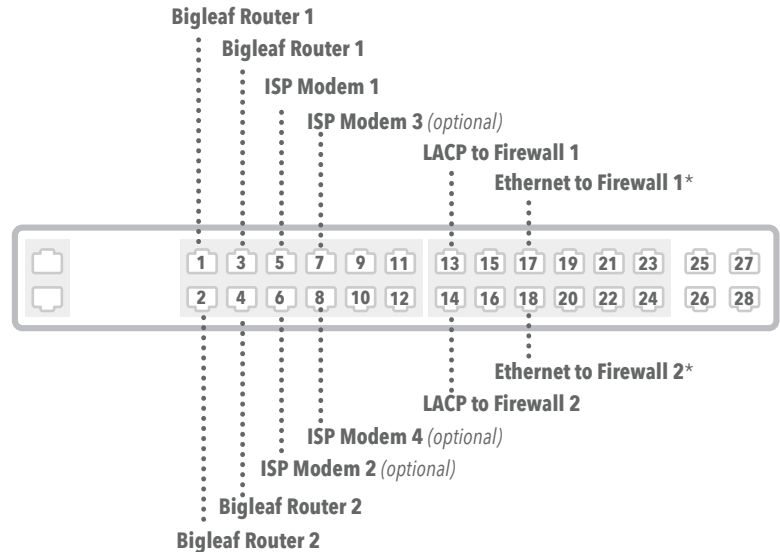

Connection Steps

The subsequent pages will cover Steps 4 - 7 in greater detail.

The number of connections in Step 6 will vary based on your WAN configuration. See your Configuration Details card for your WAN assignments.

Step 7 has two main options for connecting your firewall(s). You can use LACP for maximum redundancy, or single Ethernet connections if your firewalls do not support LACP.

Step 4

Switches

- A Switch 1, Stack 1 to Switch 2, Stack 1
- B Switch 1, Stack 2 to Switch 2, Stack 2

Step 5

Bigleaf Router 1

- C Switch 1, Port 1 to Router 1, Port WAN 1
- D Switch 1, Port 3 to Router 1, Port WAN 3
- E Switch 2, Port 1 to Router 1, Port WAN 2
- F Switch 2, Port 3 to Router 1, Port WAN 4

Step 6

Bigleaf Router 2

- G Switch 1, Port 2 to Router 2, Port WAN 1
- H Switch 1, Port 4 to Router 2, Port WAN 3
- I Switch 2, Port 2 to Router 2, Port WAN 2
- J Switch 2, Port 4 to Router 2, Port WAN 4

Step 7

ISP Modems

- K ISP Modem 1 to Switch 1, Port 5
- L ISP Modem 2 to Switch 2, Port 6
- M ISP Modem 3 to Switch 1, Port 7
- N ISP Modem 4 to Switch 2, Port 8

Step 8

Firewalls

- O Firewall 1, Port WAN 1 to Switch 1, Port 13
 - P Firewall 1, Port WAN 2 to Switch 2, Port 13
 - Q Firewall 2, Port WAN 1 to Switch 1, Port 14
 - R Firewall 2, Port WAN 2 to Switch 2, Port 14
- or
- S Firewall 1, WAN Port to Switch 1, Port 17
 - T Firewall 2, WAN Port to Switch 2, Port 18

Option 1

Option 2

4 Connect Switches Together

Using Stackwise cables, connect the two switches together. The switch-to-switch connections allow the switches to function as a unified pair for redundancy. This step is critical to ensure proper operation of the HA system.

SWITCH-TO-SWITCH CONNECTIONS

- A Switch 1, Stack 1 to Switch 2, Stack 1
- B Switch 1, Stack 2 to Switch 2, Stack 2

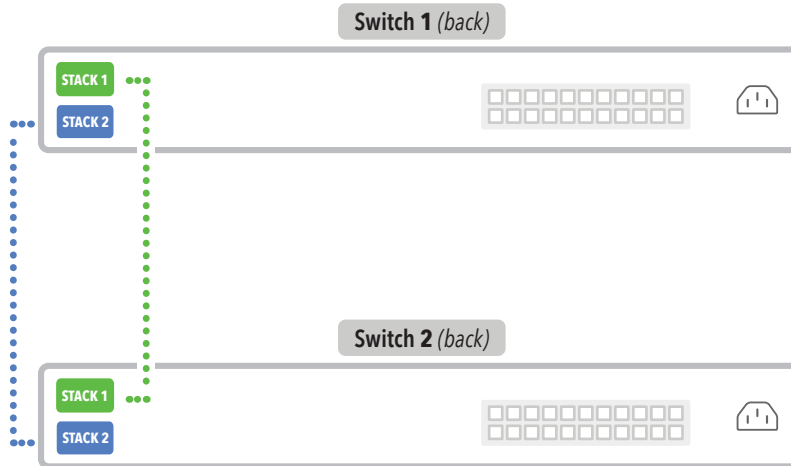



DO NOT PROCEED

until you have completed Step 4. Failure to connect the switches together will result in reduced redundancy and improper operation.

5 Connect Bigleaf Router 1 to Switches

Connect the Bigleaf Router 1 to the switches as outlined below in connections C through F.

SWITCH 1 CONNECTIONS

- C Switch 1, Port 1 to Router 1, Port **WAN 1**
- D Switch 1, Port 3 to Router 1, Port **WAN 3**

SWITCH 2 CONNECTIONS

- E Switch 2, Port 1 to Router 1, Port **WAN 2**
- F Switch 2, Port 3 to Router 1, Port **WAN 4**

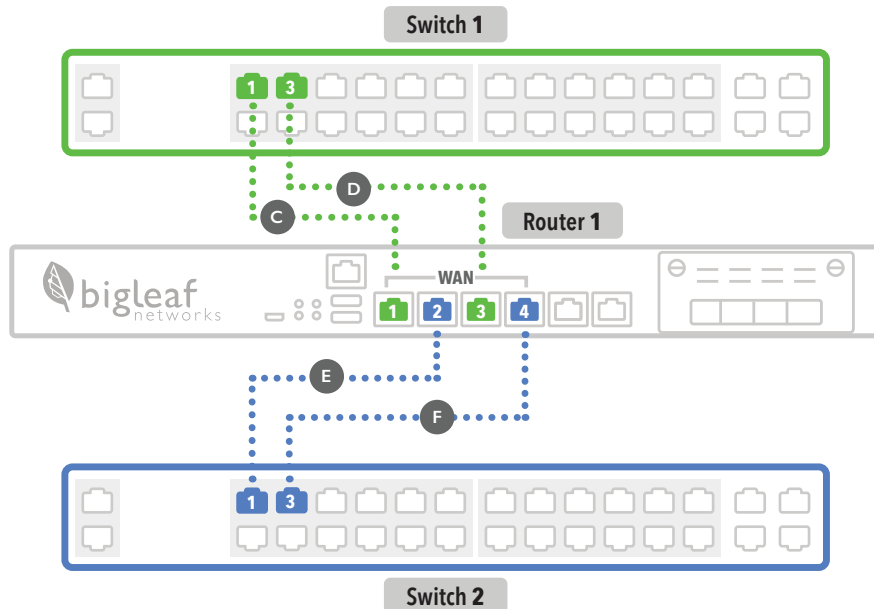

6 Connect Bigleaf Router 2 to Switches

Connect the Bigleaf Router 2 to the switches as outlined below in connections G through J.

SWITCH 1 CONNECTIONS

- G Switch 1, Port 2 to Router 2, Port WAN 1
- H Switch 1, Port 4 to Router 2, Port WAN 3

SWITCH 2 CONNECTIONS

- I Switch 2, Port 2 to Router 2, Port WAN 2
- J Switch 2, Port 4 to Router 2, Port WAN 4

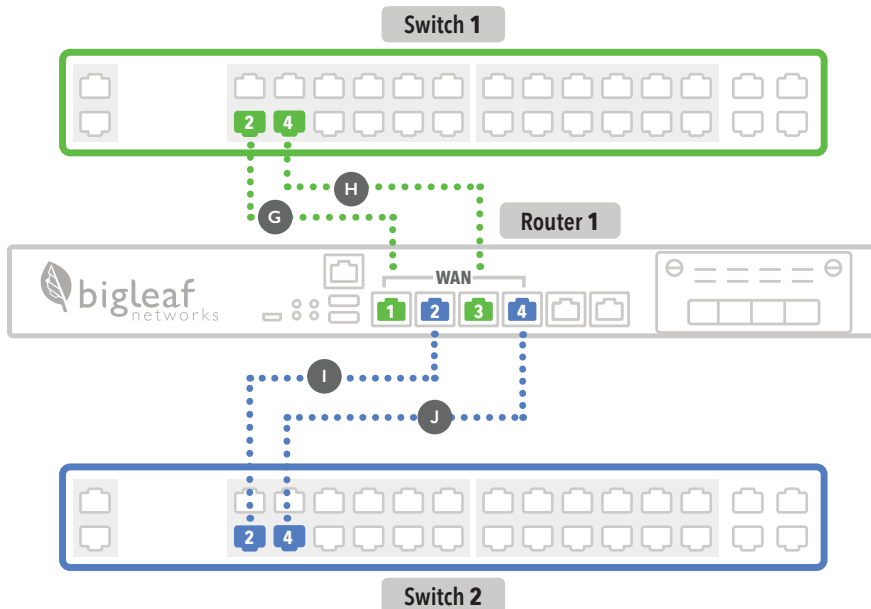

7 Connect ISP Modems to Switches

Plug each ISP circuit into the correct switch port as assigned on your Configuration Details card. You may have up to four connections.

ISP MODEM 1 CONNECTIONS

K ISP Modem 1 to Switch 1, Port 5

ISP MODEM 2 CONNECTIONS

L ISP Modem 2 to Switch 2, Port 6

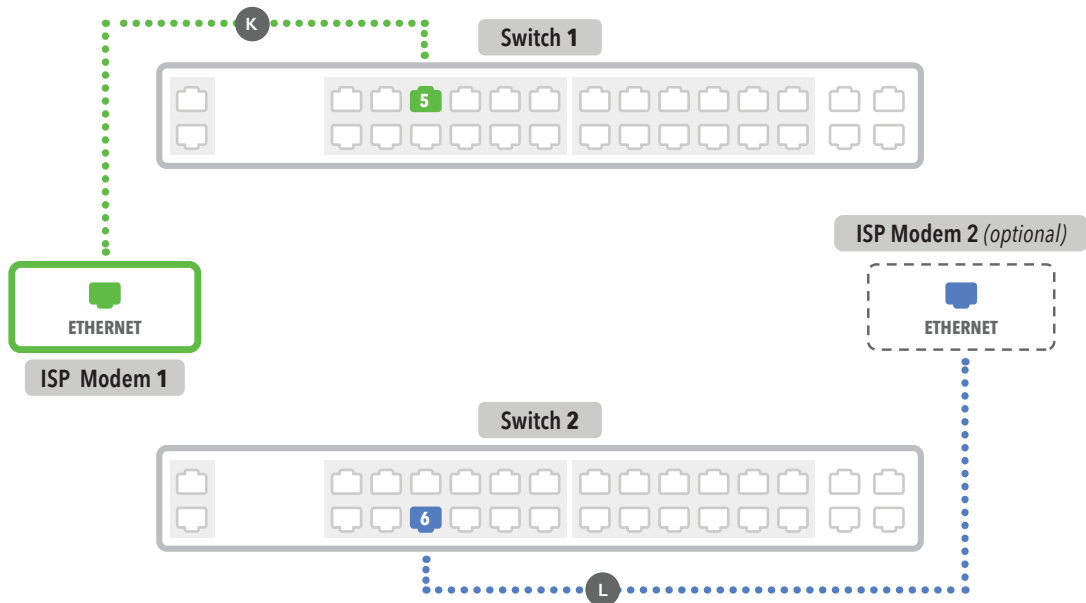

ISP MODEM 3 CONNECTIONS

M ISP Modem 3 to Switch 1, Port 7

ISP MODEM 4 CONNECTIONS

N ISP Modem 4 to Switch 2, Port 8

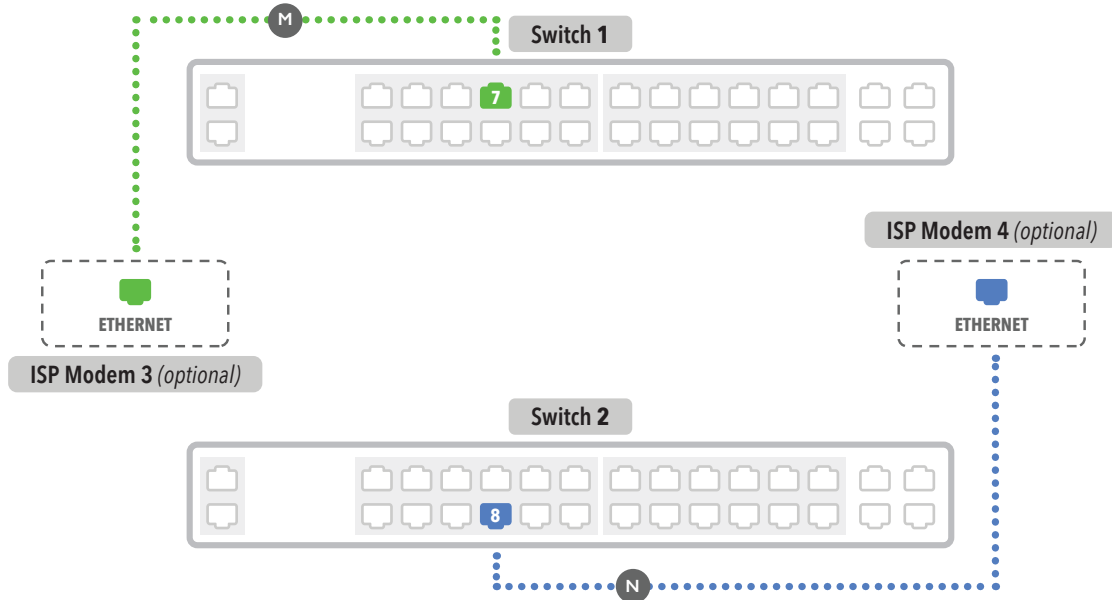

8 Connect Firewalls to Switches

Choose between LACP or Ethernet hand-off to your firewall(s). Note that Firewall 2 is optional.

Option 1 LACP Hand-off

FIREWALL 1 CONNECTIONS

- O** Firewall 1, Port **WAN 1** to Switch 1, Port **13**
- P** Firewall 1, Port **WAN 2** to Switch 2, Port **13**

FIREWALL 2 CONNECTIONS

- Q** Firewall 2, Port **WAN 1** to Switch 1, Port **14**
- R** Firewall 2, Port **WAN 2** to Switch 2, Port **14**

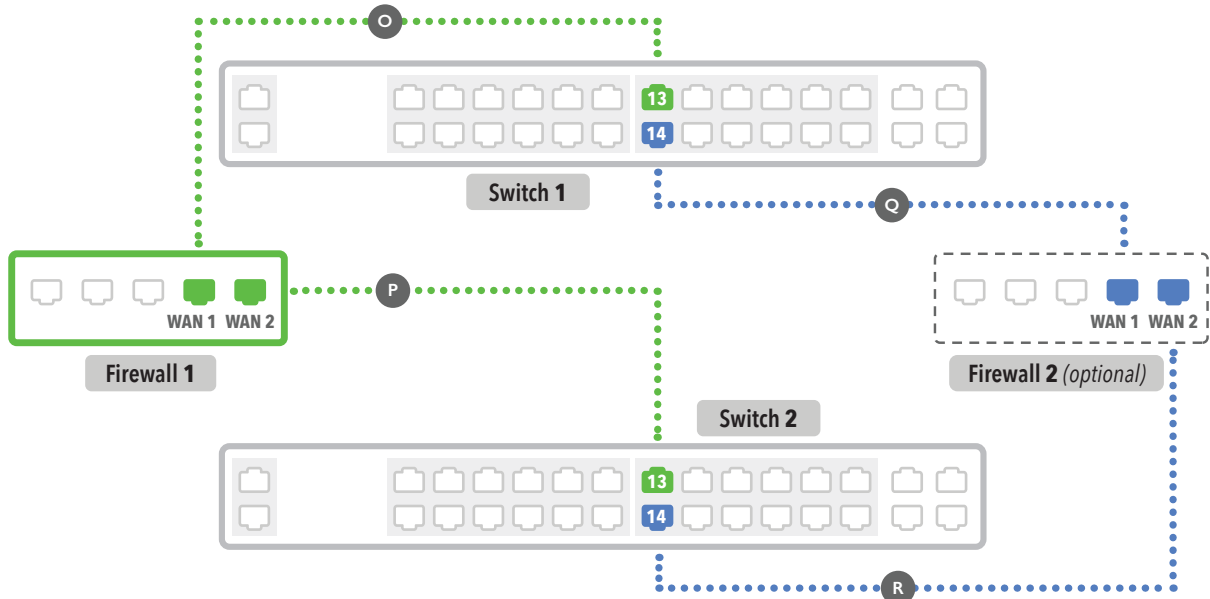

Option

2

Ethernet Hand-off*

FIREWALL 1 CONNECTIONS

S Firewall 1, **WAN Port** to Switch 1, Port 17

FIREWALL 2 CONNECTIONS

T Firewall 2, **WAN Port** to Switch 2, Port 18

**Some firewalls support Ethernet "port redundancy," which you can use by connecting Firewall 1 to Port 17 on both switches and Firewall 2 to Port 18 on both switches.*

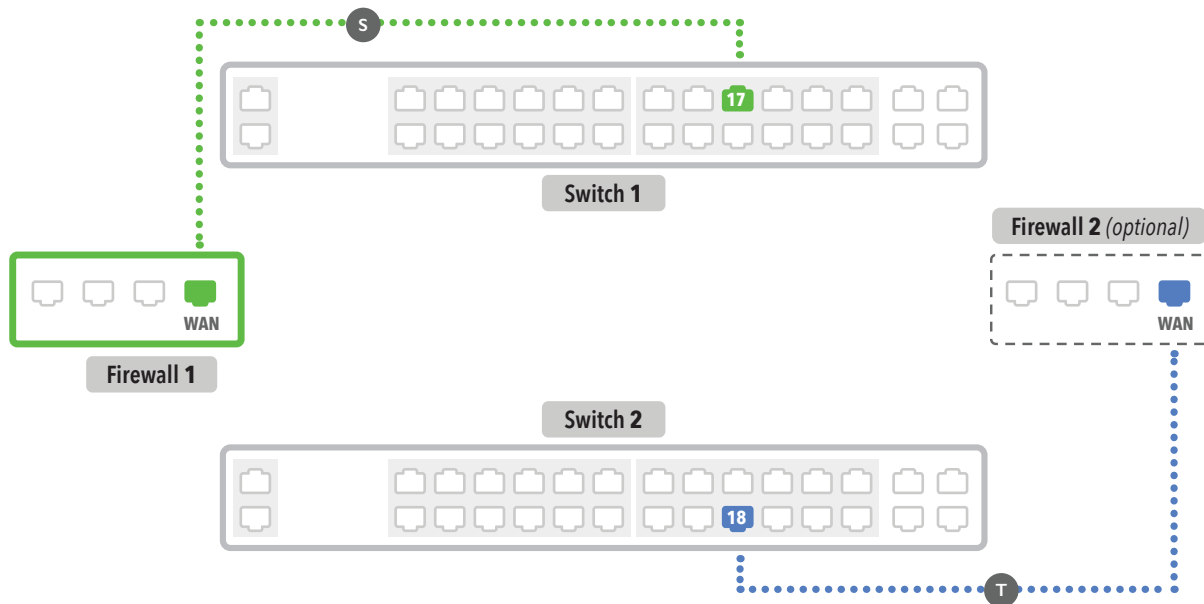

9 Plug Hardware into a Power Source

Before proceeding, you may want to refer to the switch connection steps outlined in Step 3 to verify that all cables have been connected to the switches correctly. The enclosed power cables may vary depending on the router/switch models.

Using the ports on the back of the devices, plug the Bigleaf routers and switches into a power source. To keep redundancy, we recommend using two separate power sources with UPS protection.

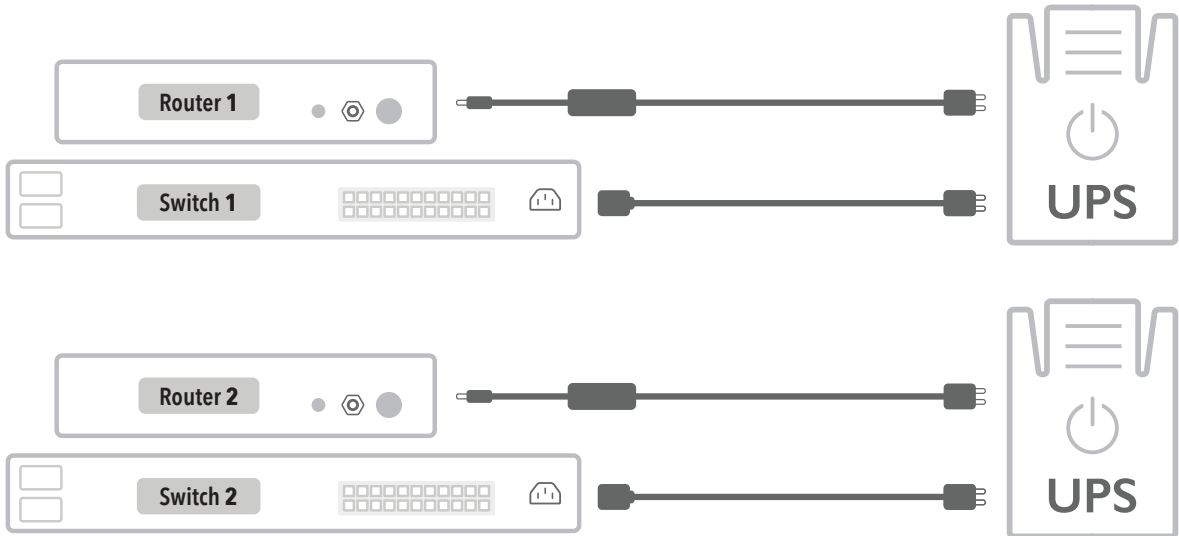

10 Configure Your Equipment

To connect your network to the Bigleaf service, re-configure your firewall(s) or router(s) that are connected to the switches.

Log in to your firewall or router interface and enable auto-negotiation.

Change your interface settings based on your setup:

LACP

- Enable LACP link aggregation
- Set LACP rate or mode as "fast" if available

Non-LACP Port Redundancy Protocol

Configure that setting in accordance to your firewall's documentation.

Single Ethernet Hand-Off

No action required

Navigate to the page where you set the WAN or Internet IP address. Input the information for the fields listed on your Configuration Details card.

Save and apply the new configuration. You may need to reboot your device(s).

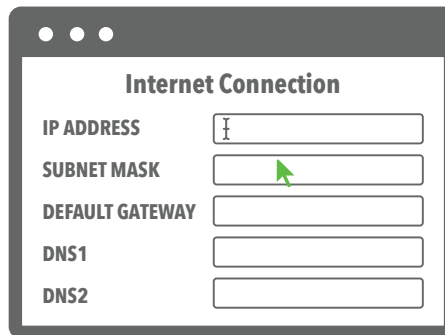

The image shows a screenshot of a configuration window titled "Internet Connection". It contains five input fields, each with a label to its left: "IP ADDRESS", "SUBNET MASK", "DEFAULT GATEWAY", "DNS1", and "DNS2". A mouse cursor is pointing at the "SUBNET MASK" field. The window has a dark grey header and three small white circles in the top-left corner, suggesting it's a browser window or a software interface.

11

Test Connection and Make Final Updates

You should now be up and running on your Bigleaf service. If you identified any IP-related changes in Step 2, make those changes now.

Run a test or two, like browsing to a website, to make sure connectivity is working properly.

If things look good, proceed by changing any DNS records or IP-specific network resources that you identified in Step 2.

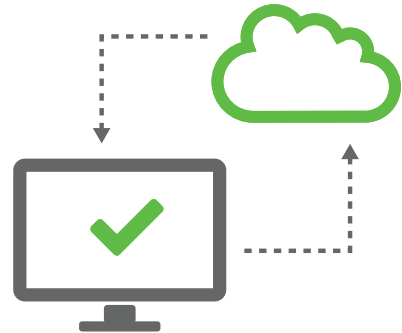

CONGRATS

Your setup should now be complete.



About Bigleaf Networks

Bigleaf Networks improves Cloud connectivity and Internet performance. We are a team of telecom and network software professionals who built our SD-WAN optimization and redundancy service based on the natural architecture of leaves. We are dedicated to providing a better Internet experience with simple implementation, friendly support, and powerful technology. Founded in 2013, Bigleaf Networks is investor-backed, offering nationwide service.

Simply Stay Connected.

(888) 244-3133 / +1 (503) 985-8298 / support@bigleaf.net / www.bigleaf.net